

Turning a Teleidoscope

Supplies Needed

- Faceplate
- Hardwood Waste Block
- Revolving Center
- Flexible Adhesive
- Sandpaper/Finish
- Drilled Blank
- Eye and Ear Protection
- Scotch Tape

Mounting the Waste Block

1. Mount a 3 1/2" x 3 1/2" x 2" hardwood waste block to the faceplate with 1" screws.

Turning the Waste Block Drive Center

1. Turn a tapered tenon to fit snugly into the 1 1/4" drilled hole in the teleidoscope blank. This will center the blank and provide a drive center to turn the blank. Cut a 1/8" shoulder, this will stop the barrel from sliding up the tenon (figure 1). If too much pressure is applied or the tenon is too large, the teleidoscope blank may split.

Figure 1

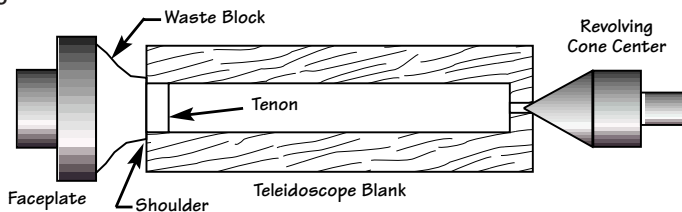

Rough turning the teleidoscope blank

1. Mount the blank between the waste block drive tenon and a revolving cone center. Make sure that the blank is firmly between centers by rotating the blank by hand. Rough turn the blank removing the corners and flat spots until you have a cylinder. Note that one end of the blank may have a larger diameter than the other (figure 2), this is caused by the drill bit wandering when drilling deep holes.

Figure 2

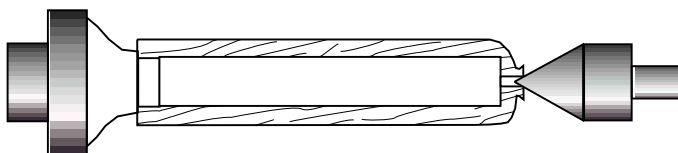

Sand and Finish

1. Sand and finish the teleidoscope barrel to your own specifications.

Drilling the viewing hole

1. Remove the finished blank from the lathe. Enlarge the viewing hole with a 5/16" drill bit. Hand sand the new 5/16" view hole and the 1 1/4" hole to remove any burrs.

Figure 3



Tips on Handling the Mirror Surfaces

1. Don't remove the protective lamination until you are ready to use the mirror. After the lamination is removed, always hold the mirror by the edges, and put it down with the aluminized side up.
2. After removing the plastic lamination, you may forget which side of the mirror is the aluminized front surface. Place the point of a pencil lightly on the surface of the mirror. If there appears to be a space between the pencil point and its reflection, this is the back of the mirror. However, if the pencil point seems to touch its reflection, this is the aluminized front surface.
3. If the aluminized side of the mirror gets dirty, marked, or fingerprinted, wipe it with acetone on a cotton ball. To avoid streaking, wipe with slow even strokes, allowing the acetone to dry as you wipe. Don't worry, small scratches, pin holes, or even small chips in the ends of the mirrors won't hurt the image in your kaleidoscope. However, dirt will!!

Teleidoscope Mirror Assembly

1. Stick three pieces of scotch tape approximately 3 1/2" long across the back (unlaminated) side of the narrow piece of mirror. Slightly less than 1" of tape should extend to one side of the mirror, and approximately 2" should extend to the other side. Remove the plastic lamination from the mirror and lay it on the table with the tape "sticky side" up. (see figure 4)

Figure 4

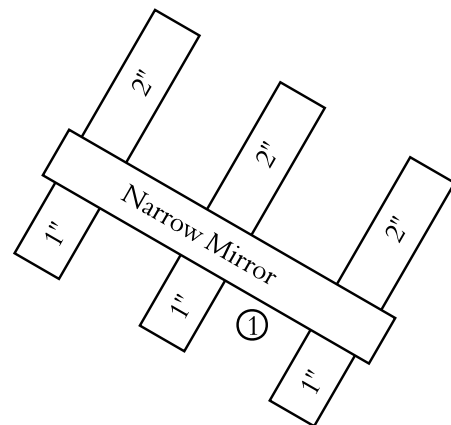

The tape is attached to the narrow mirror.

- Remove the lamination from one of the wider pieces of mirror. Stand it on its long edge on top of the 1" lengths of tape so that it is butting tightly against the edge of the narrow piece of mirror. Make sure that the aluminized surface of the second mirror is facing inward toward the narrow mirror. Lean this mirror in so that its top edge is directly over the center of the narrow piece of mirror. Be sure that the seam where the two mirrors butt together is tight with no gap. Now stick the tape up the side of the second piece of mirror to hold it firmly in place. (figure 5)

Figure 5

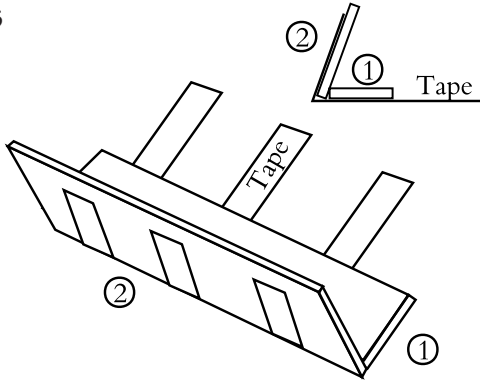

The second mirror is butted tightly against the first mirror.

- Remove the lamination from the third piece of mirror. Stand it on its long edge on top of the 2" lengths of tape so that it is butting tightly against the remaining edge of the narrow piece of mirror. Make sure that the aluminized side of the mirror is facing inward. Lean the third mirror so that it meets the second mirror edge to edge (not overlapping) over the center of the narrow mirror. Now stick the tape up the side of the third mirror, and continue to wrap the tape until it is all used. Take care to maintain the proper alignment of the mirror triangle as shown in figure 6. Note that the narrow piece of mirror is held in between the two wider pieces. (see figure 6)

Figure 6

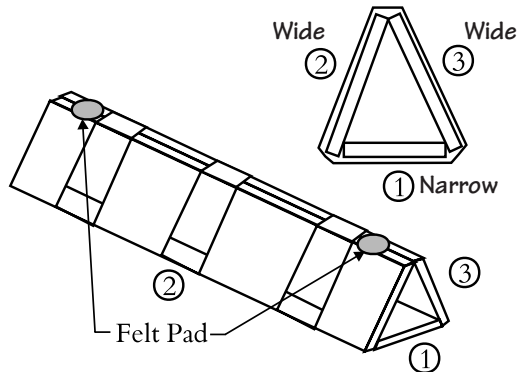

The third mirror completes the triangle.

- To further tighten the seams, add two more bands of tape between the original three bands. Rotate the mirror prism as you tape, pinching the seams together.

- When the mirrors are securely taped together, put a felt pad on each point on the top of the triangle. Use extra layers of tape if necessary to make the mirrors fit tightly in the tube. (see figure 6)
- Only one dust cover needs to be used to cover the viewing hole. The plastic ball will act as a dust cover for the other end of the mirrors.
- Slide the assembled mirrors into the 1 1/16" hole and check for a snug fit.
- Glue the acrylic ball into the large hole of the turned blank. Carefully place several dots of clear flexible adhesive around the inside edge of the opening. Firmly push the ball into the opening making sure it comes in contact with the glue. Place the Teleidoscope vertically against a wall with the ball down to allow the adhesive to cure.

Figure 7

