

Turning a Game Call

Supplies Needed

- 1 1/2" x 1 1/2" x 6 1/8" Blank
- Game Call Kit
- Pen Mandrel
- Set of Bushings
- Glue (Thick CA or Epoxy)
- Sandpaper/Finish
- Drill or Drill Press
- Eye and Ear Protection

Wood Preparation

1. Select a blank 1 1/2" x 1 1/2" x 6 1/8".
2. Cut the blank to the sizes listed below.
3. Mark and drill the blanks as shown below. 3/4" diameter hole for the tone chamber. 31/64" diameter hole for the stopper.

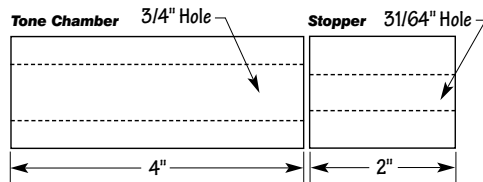

Turning the Tone Chamber

1. Mount the turning kit onto a pen mandrel as shown below.
2. Slide the tone chamber blank onto the mandrel and tighten the knurled knob firmly in order to compress the rubber expansion tubes properly so the blank will not slip while turning.
3. Turn the blank to the desired shape. Note: make a 3/16" wide groove for the lanyard if so desired.
4. Sand and finish all exposed surfaces of the turned tone chamber.

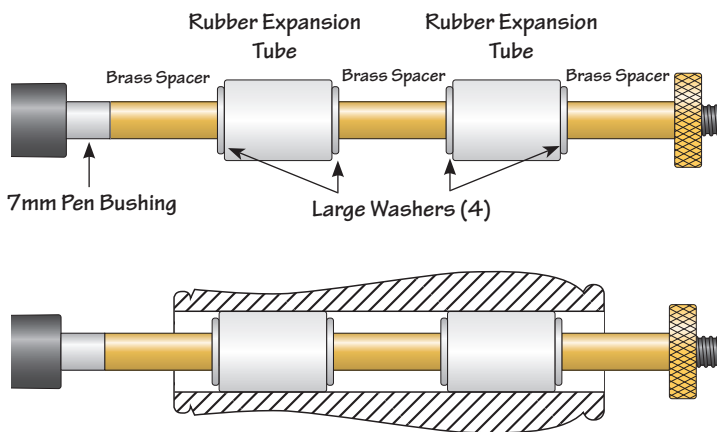

Turning the Stopper

1. Mount the turning kit onto a pen mandrel as shown below.
2. Slide the stopper blank onto the mandrel and tighten the knurled knob firmly in order to compress the rubber expansion tubes properly so the blank will not slip while turning.
3. Turn a 3/4" dia. tenon that will fit into the tone chamber. Use the metal taper gauge (supplied in the game call turning kit) to size the tenon. Test the fit of the stopper tenon by stopping the lathe, removing the knurled knob from the mandrel, and sliding the tone chamber over the end of the mandrel and onto the stopper tenon. This step may need to be repeated several times. **Do not to remove the stopper from the mandrel, as this will alter the alignment.**
4. Cut a two grooves in the tenon using the point of a skew to accept the o-rings.
5. Sand and finish all exposed surfaces of the turned stopper.

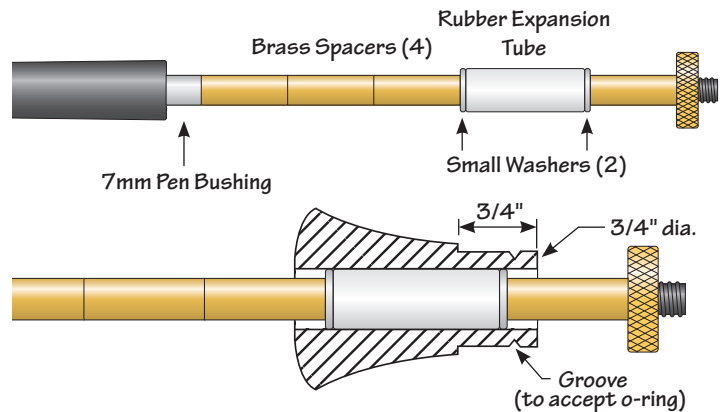

Assembly

1. Insert the end of the reed assembly into the stopper tenon.
2. Insert the complete stopper assembly into the tone chamber to complete the call.

Note: The stopper hole has been drilled slightly under sized for reed fitting purposes. As a result, the stopper hole may need to be slightly enlarged. Wrap sandpaper around the end of a dowel and sand the hole until a proper fit is achieved.

Hint: If your call does not sound proper, remove the reed from the reed assembly and turn it over.

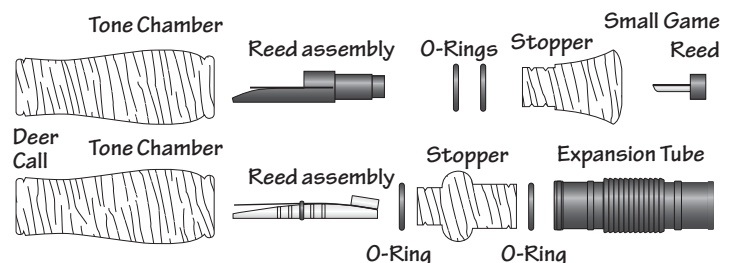

Plastic Canada & Speckle Belly Reed

Assemble the reed parts as shown at right. One end of the reed wedge has an arrow on it. This end goes first into the stopper hole.

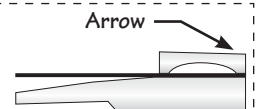

Turning the Deer Stopper

1. Mount the turning kit onto a pen mandrel as shown below.
2. Slide the stopper blank onto the mandrel and tighten the knurled knob firmly in order to compress the rubber expansion tubes properly so the blank will not slip while turning.
3. Turn a $3/4$ " dia. tenon $1/2$ " long that will fit into the tone chamber. Use the metal taper gauge (supplied in the game call turning kit) to size the tenon. Test the fit of the stopper tenon by stopping the lathe, removing the knurled knob from the mandrel, and sliding the tone chamber over the end of the mandrel and onto the stopper tenon. This step may need to be repeated several times. **Do not to remove the stopper from the mandrel, as this will alter the alignment.**
4. Turn a $7/8$ " diameter tenon $7/8$ " long on the other end of the stopper for the expansion tube.
5. Cut a groove in each tenon using the point of a skew to accept the o-rings. (see figure below)
6. Sand and finish all exposed surfaces of the turned stopper.

