

Easy Wood Tools

from Jackson Woodworking LLC

For Your Safety

If you do not understand **ALL** of these precautions, do not use this tool.

- *Read and understand your lathe owner's manual
- *Watch the enclosed instructional video until you understand the concepts involved in using the C11 tool
- *Set tool rest height to align top of cutter with spindle center
- Keep work area clean
- Keep children away
- Don't force the tool
- Use the right tool for the job
- Wear safe and protective clothing
- Wear safety glasses and/or face shield
- Keep tools sharp
- Use Dust Mask
- Don't mix drugs and machinery
- Secure work piece properly
- Pay attention

Enclosed DVD can be watched on most any DVD player .

www.easywoodtools.com

All views are from above the lathe.
 All cuts- Tool handle level to floor
 and tool flat on tool rest.

Method #1

There are three directions of possible cuts- left, right or plunge (end)

For all cuts- You should only be cutting with one edge (primary) at a time. The secondary edge in contact should be allowed to slightly contact the work and improve the surface as it follows the primary cutting edge.

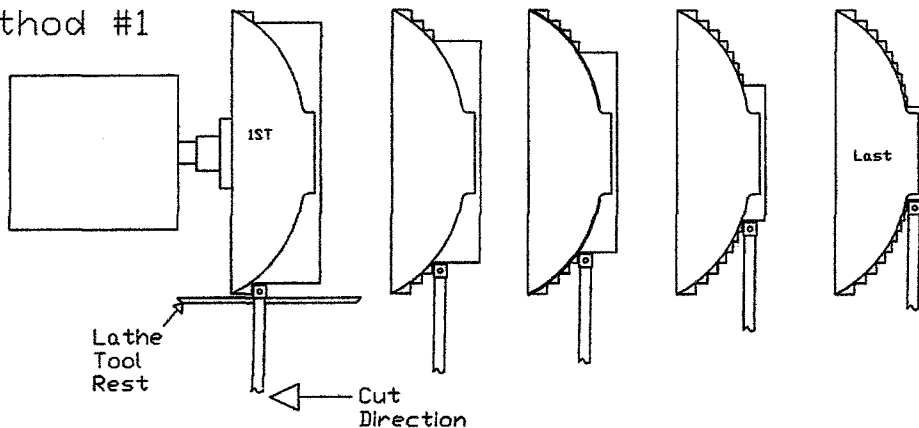

OR Method #2

* This is a plunge cut and uses the end cutting edge of the insert only. The right cutting edge is allowed to touch just enough to improve surface.

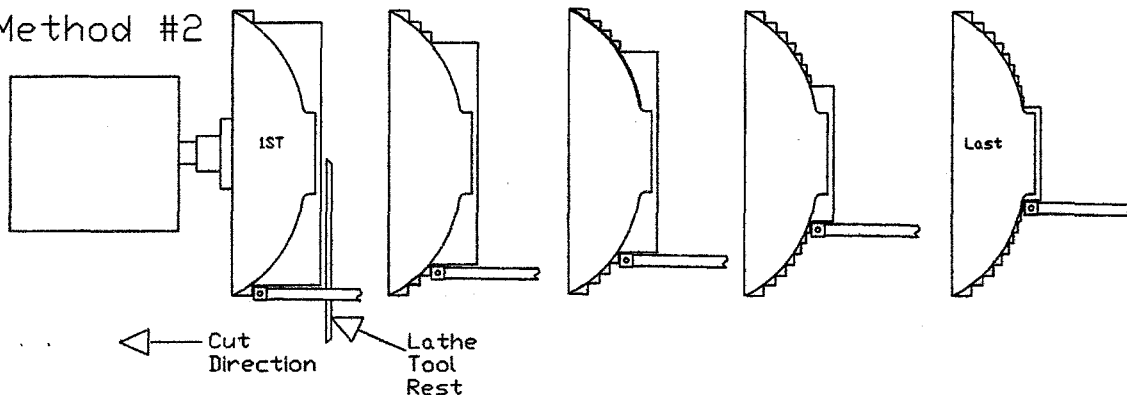

Finish Pass

* This is a left hand cut and uses the left cutting edge of the insert only.
 * Handle should be a little ahead of cutter to allow end cutting edge to improve finish.

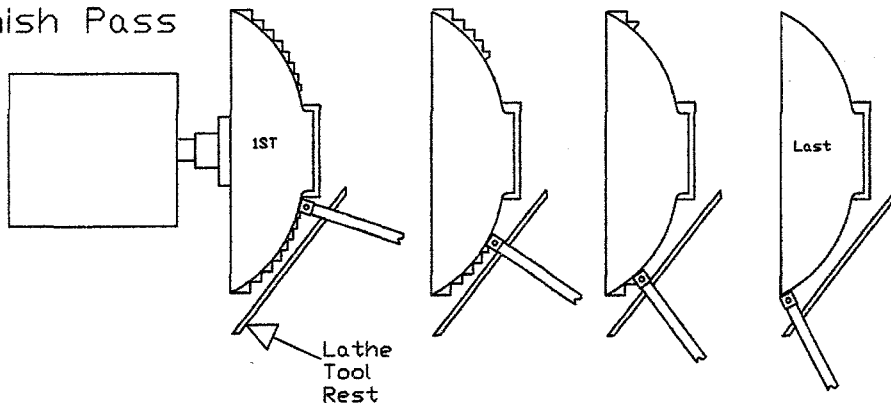

For inside work- step out from the center. You may want to remove the center most material with a 1 1/2" forster bit in a jacobs chuck or use a conventional bowl gouge.

