

Deluxe Magnetic Paper Clip Ring

Supplies Needed

- Blank
- Glue (Thick CA or Epoxy)
- Sandpaper/Finish
- Chuck or Faceplate
- Double Sided Tape
- Eye and Ear Protection

Chuck Method

1. Mount the blank in a chuck and turn a dovetail recess into the blank (see below). Sand and finish the inside recess walls and bottom of the wood as this will be your last chance to finish these areas.
2. Remove the blank from the chuck and reverse it in the chuck.
3. Rough turn the blank to desired shape.
4. Measure the magnetic ring diameter and turn a recess to fit it. You may want to test fit the ring in the recess to make sure it fits correctly. Sand and finish all remaining unfinished areas.
5. Glue the magnetic ring into the recess with some flexible adhesive.

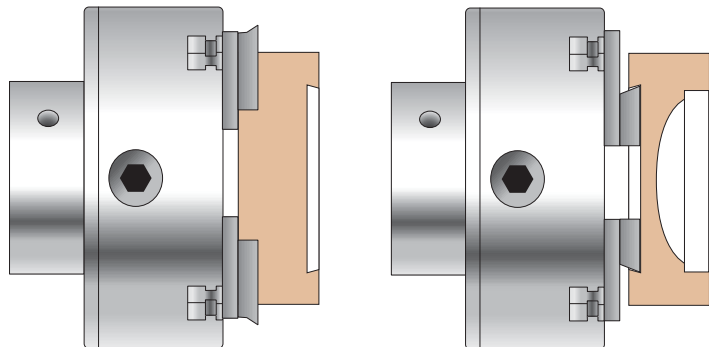

Faceplate Method

1. Mount the blank onto a faceplate and waste block using double sided tape or glue.
2. Rough turn the blank to desired shape.
3. Measure the magnetic ring diameter and turn a recess to fit it. You may want to test fit the ring in the recess to make sure it fits correctly. Sand and finish all remaining unfinished areas.
4. Glue the magnetic ring into the recess with some flexible adhesive.

