

- SPINNING THE TOP:**
- STEP 1** Tie a knot in one end of the string and a finger loop in the other end.
- STEP 2** Hold the knot against the center of the top with your thumb.
- STEP 3** Loop the free end of the string around the neck groove and cross over top of the knot. (figure 1)
- STEP 4** Holding the string tightly over the knot, pull the string down and around the tip of the top winding the string away from yourself.
- STEP 5** Place the finger loop over you middle finger and hold the top vertically (point up) in the palm of your hand. (figure 2)
- STEP 6** Throw the top across your body aiming at a spot about four feet in front of you.

TURNING INSTRUCTIONS:

- STEP 1** Select a blank 2 1/4" x 2 1/4" x 3 1/2" long.
- STEP 2** Mount the blank between centers and turn it down until it is about 2 1/8" diameter. (figure 1)

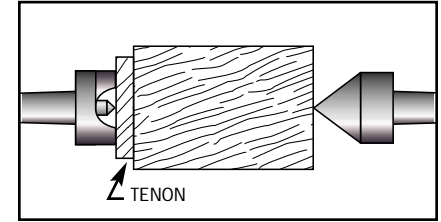

Figure 1

For Turning with a Four Jaw Chuck

- STEP 1** Cut a tenon into one end of the blank to fit the recess of your chuck jaws.
- STEP 2** Mount the blank in the chuck and advance the tailstock with revolving center up against the other end to add support while turning.
- STEP 3** Rough turn the blank shape down until slightly larger than the dimensions shown in Figure 4.

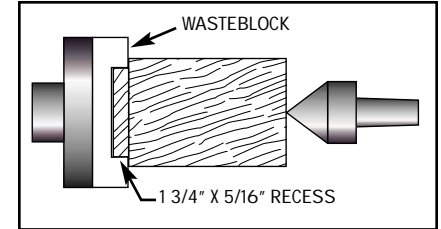

Figure 2

For Turning with a Faceplate and Waste Block

- STEP 1** Cut a 1 3/4" diameter by 1/4" wide tenon into one end of the blank and remove it from the lathe.
- STEP 2** Mount a waste block onto a faceplate and turn a 1 3/4" diameter by 5/16" deep recess in the waste block to accept the tenon of the throw top blank.
- STEP 3** Use glue to fasten the throw top blank tenon into the waste block recess. Advance the tailstock with revolving center up against the other end of the blank to act as clamp and add support while turning. (figure 2)
- STEP 4** Rough turn the blank shape down until slightly larger than the dimensions shown in Figure 4.

FINAL TURNING & ASSEMBLY:

- STEP 1** With the blank still mounted on the lathe, place a drill chuck with a 1/4" bit into the tailstock of the lathe.
- STEP 2** Drill a hole 3/4" deep into the end of the blank.
- STEP 3** Remove the drill chuck from the tailstock.
- STEP 4** Using the tailstock quill as a press, place a small scrap of wood in on the end of the tailstock quill and press the nylon throw top point into the end of the blank. (figure 3)
- STEP 5** Once the tip has been pressed into the blank, turn and finish the blank according to Figure 4.
- STEP 6** When finished turning, part the blank off with a small parting tool.

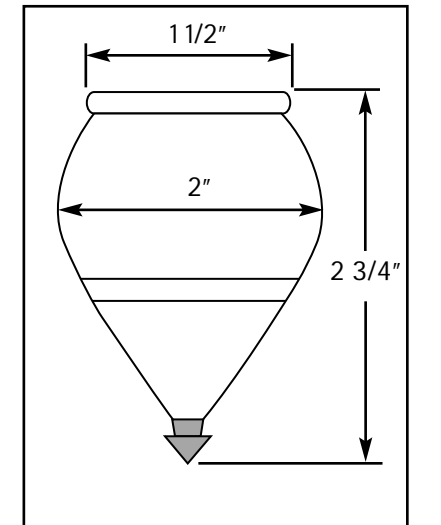

Figure 4

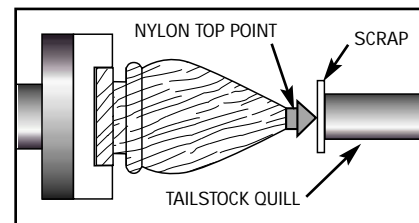

Figure 3



CRAFT SUPPLIES U S A
 Specialists in Woodturning Tools
 1287 E. 1120 S., Provo, UT 84606
 Telephone: (800) 551-8876

(198-2000)

Throw Top Instructions